

## Oldalnézet:

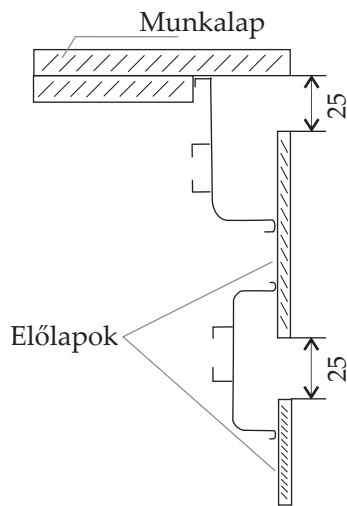

## Kliphely kialakítás:

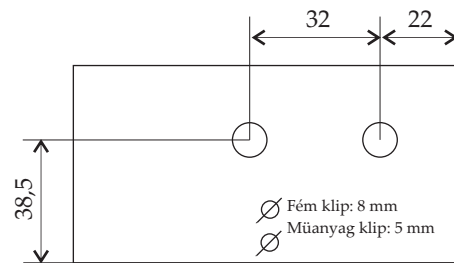

### Műanyag klip rögzítése:

- A klipet helyezük az 5 mm lyukba.
- A "H" alakú műanyagokat helyezük el a profilban.
- Illesszük helyére a profilt.
- Húzzuk rá a "H" alakot a klipre.

### Fém klip rögzítése:

- Helyezzük a műanyag alkatrészeket a 8 mm furatokba.
- Rögzítsük a klipet a műanyagba.
- Az "L" alakú fémet helyezük el a profilban.
- Illesszük helyére a profilt.
- Húzzuk rá a "L" alakot a klipre és csavarozzuk oda.

### Gola F rögzítése:

A függőleges profilt süllyesztett fejű (4.2 × 25) csavarral rögzítjük a bútorlapon keresztül, 20 mm-re a bútorlap elejétől.



**Glossy Wood Kft. 1106 Bp., Jászberényi út 29**

**e-mail: [info@glossywood.hu](mailto:info@glossywood.hu)**

**telefon: +36-20-409-79-92**

**[www.glossywood.hu](http://www.glossywood.hu)**